

# Proteus submarine

for Moebius Models®  
kit #963

**PARA  
GRAFIX™**  
P/N: PGX205

ParaGrafix states that our use of the trademarked terms listed below in our product descriptions constitutes fair use and nominative use and is in no way to offer confusion that ParaGrafix and any of the following noted trademark holders are related companies, nor do we state that we are endorsed by these trademark holders. We are an AFTERMARKET company acting in GOOD FAITH in providing high quality products to loyal customers who have already purchased products related to these trademarks. ParaGrafix is actually providing these trademark holders a venue of free advertising and indirectly provide these trademark holders with more sales leads. Moebius® is a registered trademark of Moebius Models. Fantastic Voyage ©2016 Twentieth Century Fox Film Corporation.

## INTRODUCTION

Thank you for purchasing ParaGrafix's photoetch set for Moebius Models' Proteus Submarine kit. This set is intended for modelers of modest experience

### Materials

In addition to the photoetch, you will also need scissors or a knife\* to remove individual pieces from the main fret, a file to remove material left from cutting, and super glue (aka CA or cyanoacrylate).

\* We prefer a #17 Xacto chisel blade and/or a specialty set of scissors like Xuron's model 9180ET.

\*\* Extreme care must be taken when using razor blades. Risk of serious injury.

### Raised Detail

Where applicable, these instructions note an area where the raised kit detail must be removed. The symbol at left will show you where this needs to happen. This may be done in whatever way you are most comfortable: sanding, filing, chiseling. Note that in most cases the surface does not need to be perfectly smooth as the photoetched part will replace the "lost" kit detail.

### Lighting Options

Unless otherwise noted, you can prep areas for lighting by removing plastic from areas where there are through holes in the photoetch. You can then backlight the photoetch. For best results, we suggest using Micro Kristal Klear from Microscale Industries ([www.microscale.com](http://www.microscale.com)) to fill the through holes. MKK can be tinted for different colored lights. MKK also works well as an adhesive for holding the backlight films in place.

### Installation Parts Order

The installation steps are not in any particular order. You can complete them as you see fit to complement your kit construction order.

### Key

Kit part (plastic):



Photoetched part:



Back-Light Film:



## Pilot Station

### Pilot Seat Support

Remove the two foot pedals from the main frame (kit part 42) and replace with photoetch parts 51. (Please note that these parts are un-numbered on the first layout of the parts). Complete construction per the kit instructions.

**NOTE:** Make sure to keep the pedal supports underneath the pedals and do not remove them.

### Instrument Cluster

Smooth out the raised detail on kit part 59 so that the control panels (etch parts 34 through 37) fit snugly. Complete construction per the kit instructions.

**NOTE:** The bottom-outside edges of 35 and 37 extend beyond the kit part. You can fill in this area with putty or sheet styrene.

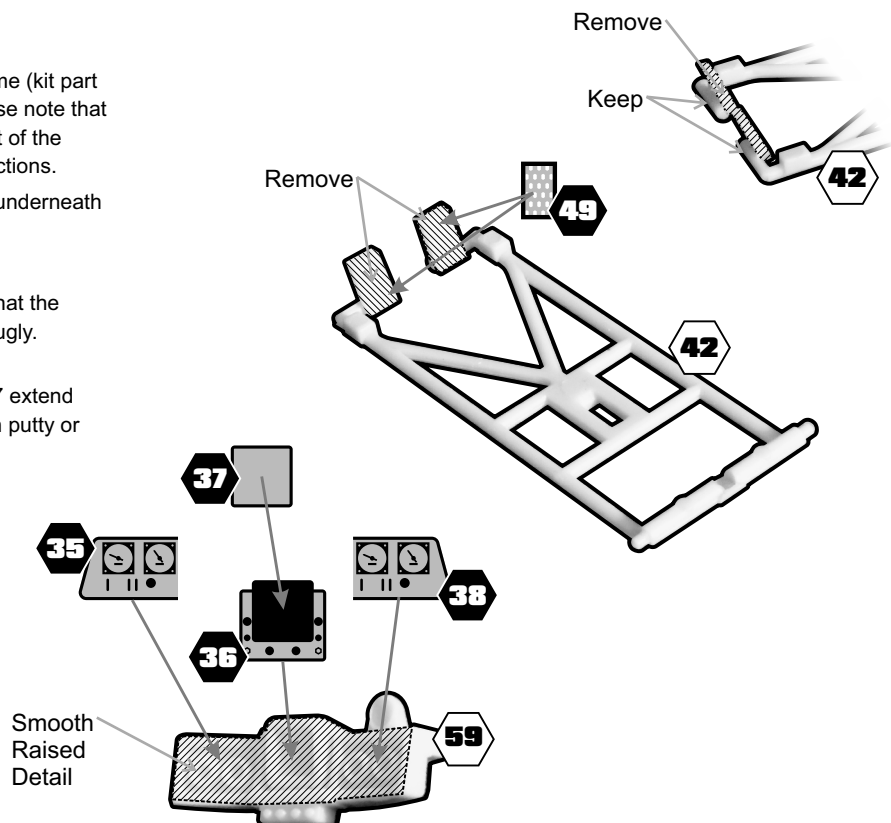

## Control Station

Remove the raised detail from kit part 53, then cut out a hole slightly larger than the opening in etch part 52.

Mount 52 to 53. Carefully trim backlight film B so that it fits in the hole on 53 and is snug up against the photoetch.

Complete construction per the kit instructions.

**NOTE:** You will want to paint the assembled part before mounting the backlight film.

**NOTE:** For a more accurate look, cover the opening the hollow back of the radio with a piece of sheet styrene.

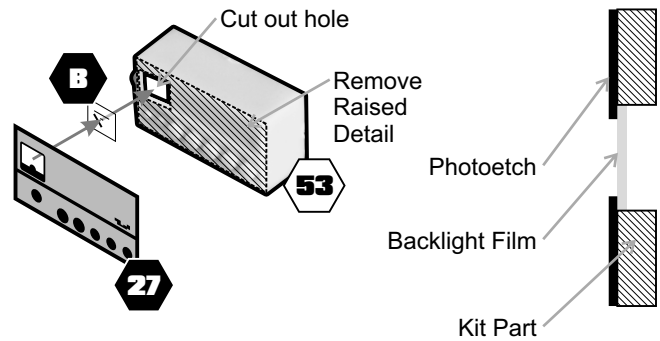

## Airlock

### Ladder Treads

Remove lower tread from the airlock chamber (kit part 28) and replace with etch part 43. Fold etch parts 42 and mount to the indentations intended for kit parts 29, 30, and 31.

### Door Tracks

Mark the side of the airlock chamber (28)  $5/32"$  and  $7/8"$  ( $4\text{mm}$  and  $22.2\text{mm}$ ) down from the upper edge as shown. Mount tracks, etch parts 13 and 14 along the marks, about  $1/32"$  ( $0.8\text{mm}$ ) short of the mounting points for the girder (kit part 79).

### Airlock Door

Fold both etch parts 44 as shown below.

Remove the four "nubbins" from the face of the door and replace with the two etch parts 44.

Attach the door per the kit instructions.

**NOTE:** The door tracks extend under the door so that you can display it open if desired. (You will have to cut out the door opening and detail the interior yourself.)

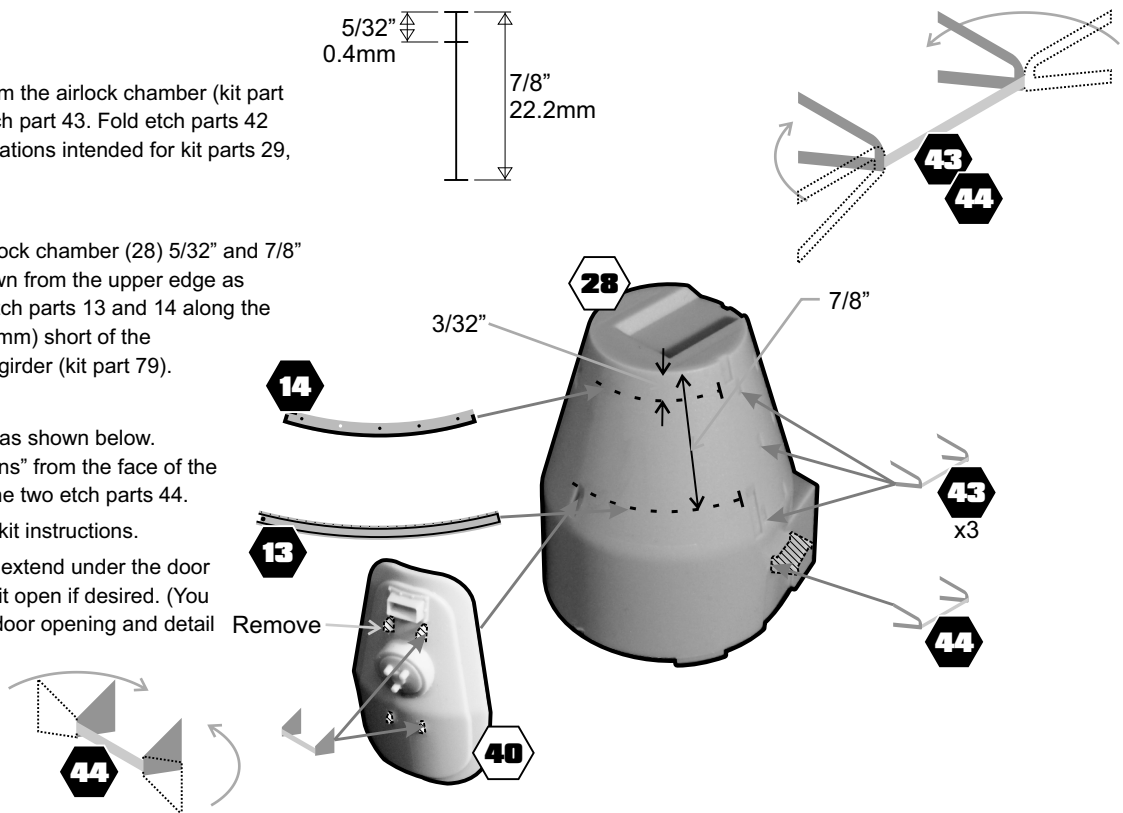

## Map Table

Remove the two small control panels and the raised detail from the large panel from part 1.

Fold etch parts 27 and 29 as shown and replace the two control panels.

Attach etch part 38 to the surface of the remaining control panel. Mount etch part 19 in the lower left-hand empty area – note that it will extend over the edge of the plastic area, you may want to fill the sides in.

Once you have completed the next step (map case) assemble the full table per the kit instructions.

**NOTE:** Fold and place another keypad (etch part 29) at the control station in front of, and to the right of, the radio. One extra keypad is included with this kit.

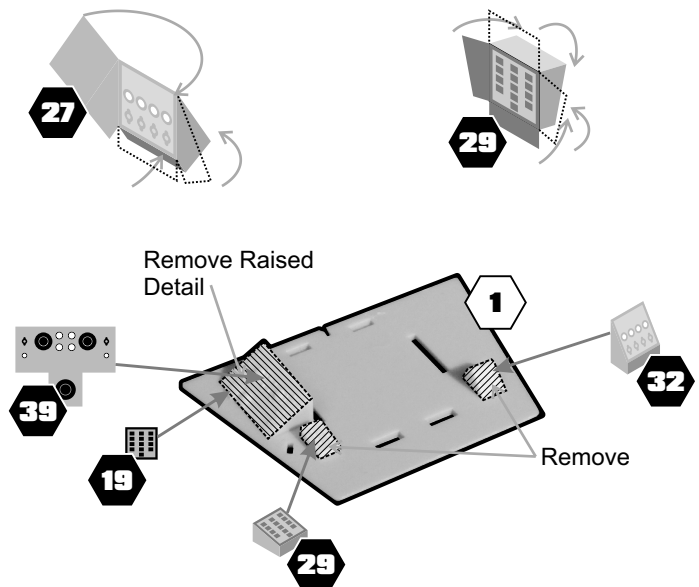

# Map Case

## Prep the Map Case Sides and Back

Remove the raised panel detail where shown on the map case sides (kit parts 23 and 24) and back (25). Cut out the hole for the backlight piece (E) and etch part on part 23. Mount etch parts 5, 7, and 20, and the backlight film

(You may find it easier to temporarily tape this assembly to the table top (19) for stability.) Assemble parts 23, 24, and 25 and temporarily tape the map case front in place.

File down the front edges of 23 and 24 so that the section is flush with the "holey" area of 20, and untape the front from the assembly.

Extend the removed areas of 23 and 24 by the thickness of the photoetch (0.01", 0.25mm).

Cut out the center map tube section from map case.

## Assembly

Attach the top and bottom portions of part 20 to the assembled map case, then add photoetch part 3. The holes in part 3 are sized to accept 0.1" (2.5mm) tubing if desired.

**OPTIONAL:** To help hold materials you may wish to add to the map case straight, you can add etch part 21. Simply fold the two tabs on the side of 21 and attach to the backside of part 3.

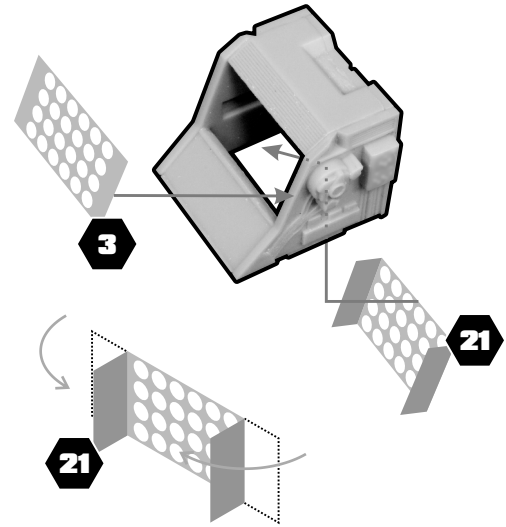
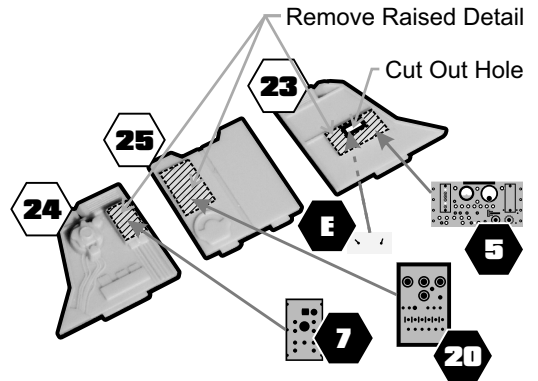
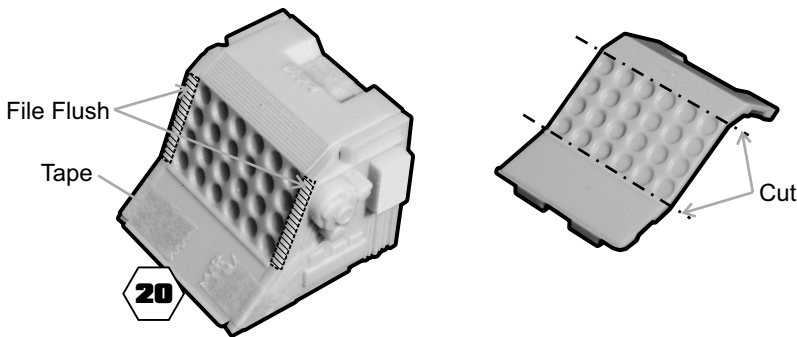

## Walls

Remove the raised control panel details on kit parts 18 and 36, and cut out spaces for the backlight films on 18. Mount the control panels and backlight films in the positions shown. Position the air vents as shown on the forward sections of the walls, along with the "elevator lights" (41).

**NOTE:** Two versions of the air vents are included. A simple single-piece vent (48) and a more accurate two-part vent (2 and 25).

**Überdetailing:** Smaller vents 47 and 49/50 are included if you use sheet styrene to fabricate new, more accurate front walls. See the next page for information creating these walls.

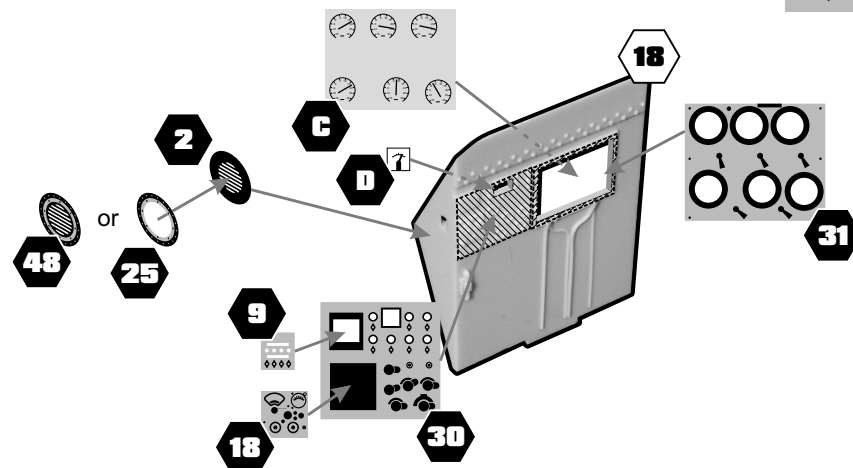
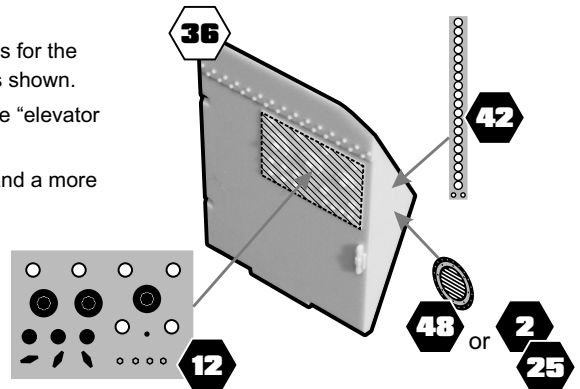

## Side Wall Modifications

The kit supplied wall extensions and shelf are not accurate to the set's interior. On the set there is no shelf. These templates allow you to create a more accurate set of interior walls.

**NOTE:** You will need a sheet of 0.040" to 0.060" sheet styrene and a section of 0.08" x 0.08" (2mm square) styrene rod. These are available at your local hobby shop or many online vendors.

Cut the two walls from your sheet styrene using the templates below. (You are free to photocopy them if you like, or print this page from the online version of our instructions.) Attach a length of the styrene rod to the top edge of kit part 3, 1 piece on each side. Now, glue the styrene sheet

**TIP:** Although we have made the templates as exact as we can, we suggest that you cut the styrene sheet roughly to shape and fine tune it to precisely fit before permanently gluing in place. You will want to test fit it with the floor unit attached to the lower hull (2), and temporarily place the upper hull (1) in place.

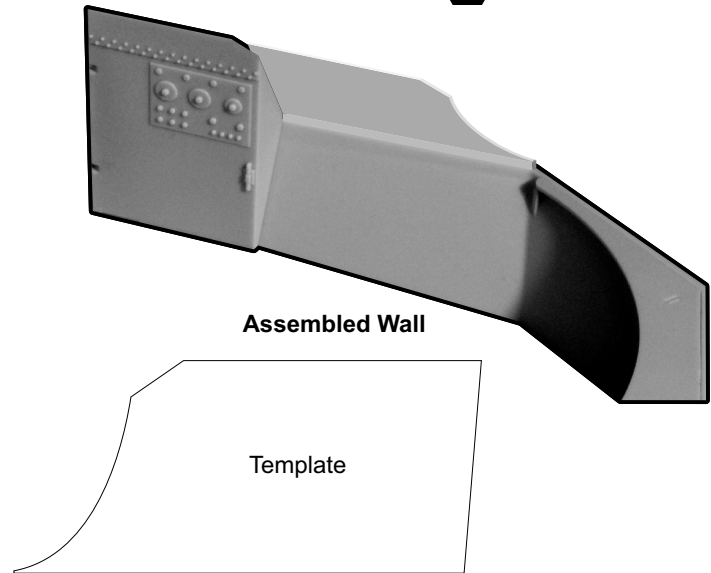
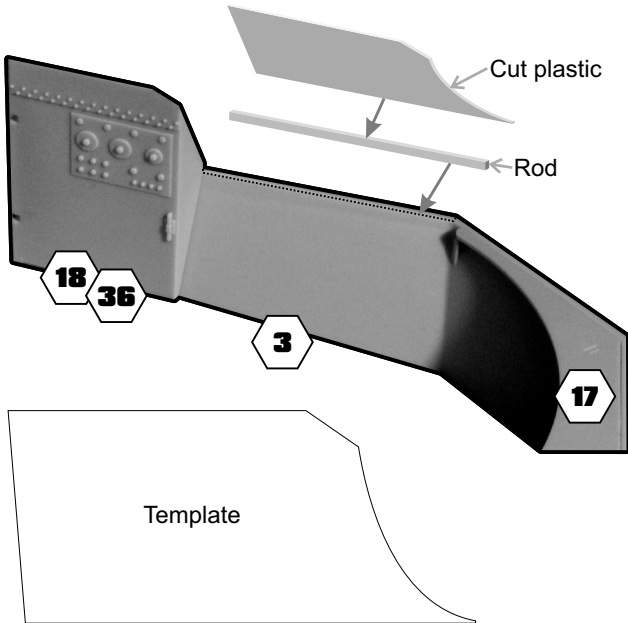
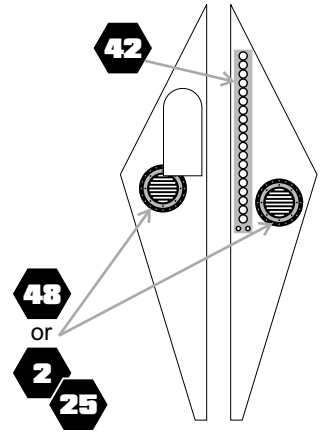

## Miscellaneous Interior Details

### Navigation Map Reader

Smooth out the surface of the reader (54) and remove a section of the face to hold the backlight film (F). Attach the photoetched face (6) and the film. Note that there are two choices of films – the blank display which is featured in the film, and a heart rate display.

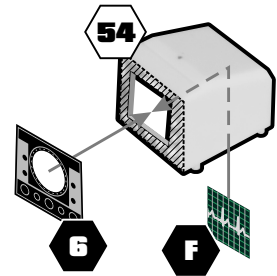

### Under the Pilot Platform Controls

Fold etch part 28 as shown below and attach to kit part 55 in place of part 56. Note that there is a hole on the backside to allow for a micro-sized LED to be installed. (Please note that the small lip on the bottom of the etch part is intentional and matches the full sized set piece.)

Remove the surface detail from kit part 57 and replace with etch part 8. Install 57/8 as shown in the kit instructions.

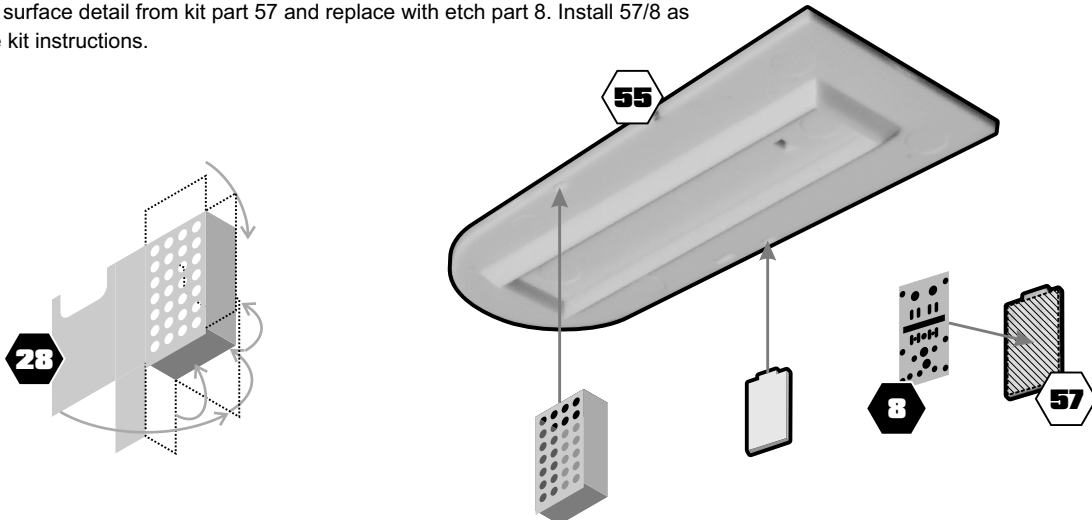

## Rear Wall and Lab

### Rear Wall

Remove the raised detail from both sides of kit part 10.

Mount the control panel and backlight film combination (23 and A, respectively) in the location of the old control panel.

Attach the air vent as shown on the rear-side of the wall. You can use either part 48, or the two part vent (25 & 48) to add extra accuracy.

**NOTE:** There is no provision for a full light box behind etch part 23. You may wish to build one out of some square or rectangular styrene rod, though this will extend the control panel out into the room.

### Laboratory FAUCET

Remove the faucet handles from kit part 36 and replace with either etch piece 45 or 46 (folded as shown).

**Überdetailing:** Use etch part 46 as a template to make a new faucet out styrene rod and sheet for a more 3D look.

### CABINET DOORS

Fold the hinges on etch parts 16, 17, 22, and 23 (or cut off and replace with sections of styrene rod). Mount etch part 23 on place of the missing door in front of the sink on kit part 36. Remove the raised handles from kit part 34 and replace them with etch parts 16 and 17.

**Überdetailing:** Cut 5/8" (15.8mm) from the forward end of the upper cabinet and use etch part 22 for the door. You will have to extend the wall of kit part 10 so that there is not a visible gap there.

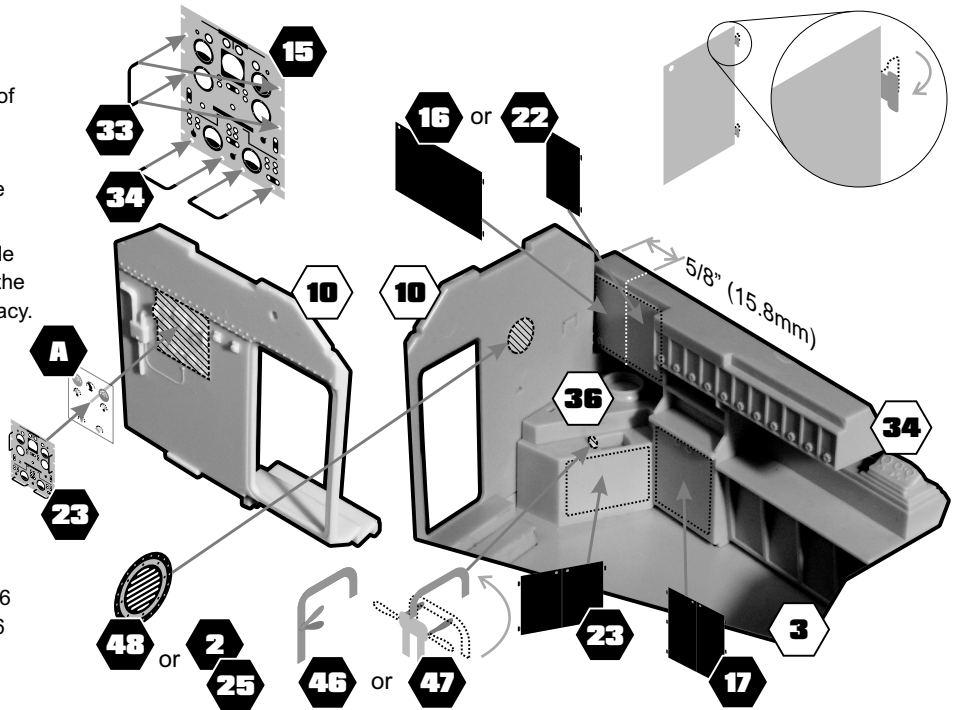

## Rudder

Fill in the two small notches at the front of kit part 21. These notches are there to fit around the kit window frames which are replaced in the next step. By doing this now, you can avoid potential damage to the photoetched parts.

Remove the raised rudder vanes and the raised trim around them (on both sides). Make sure that the new rudder vanes (etch part 24) will fit in the opening – however, don't make the opening so large that frames (10 and 11) can't be glued in place.

Attach one of the frames to the appropriate side of the rudder, then install the rudder vanes and the other side's frame.

**TIP:** You can shim each side of the rudder vanes with 0.03" (0.76mm) sheet plastic so that they fit more evenly.

**Überdetailing:** To obtain more realistic appearing vanes, you can clad each side with thin styrene shaped to a more rounded profile. Each vane is 0.22" (5.6 mm) wide.

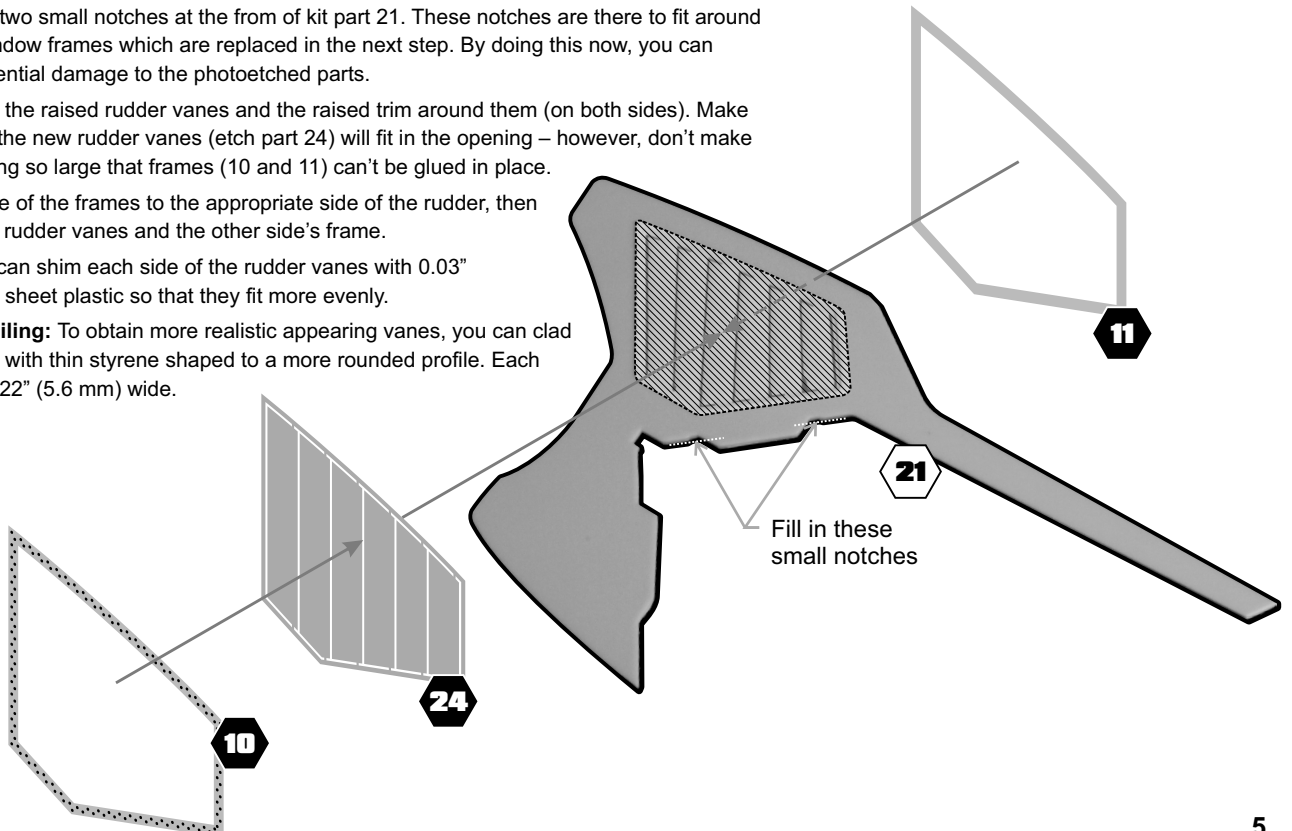

## Laboratory Window Frames

Remove the raised window frames from kit part 1. Then replace with etch parts 40 and 41.

**TIP:** Install the window frames after the rudder so that the frames fit flush against the rudder.

**Überdetailing:** Cut out the window area and replace with clear plastic sheet. This will allow you to see into the laboratory.

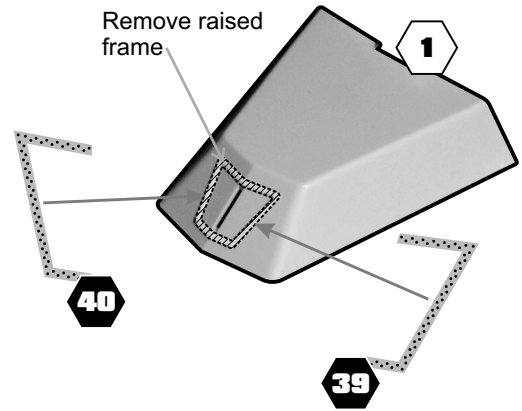

## Pilot Station Lamps

Curve etch part 1 into a circle with the "ridges" facing in and glue the two ends together (there is a slight overlap built in to accommodate glueing).

If using super glue (aka CA) allow the glue to fully set so that it doesn't craze the clear styrene. Insert the finished piece inside kit part 6. If you want to secure the etch piece in place, we suggest using a clear glue like Micro Krystal Klear or Testors Clear Parts Adhesive and Window Maker – though this shouldn't be necessary as the part will be held in place naturally when the dome is attached to the upper hull.

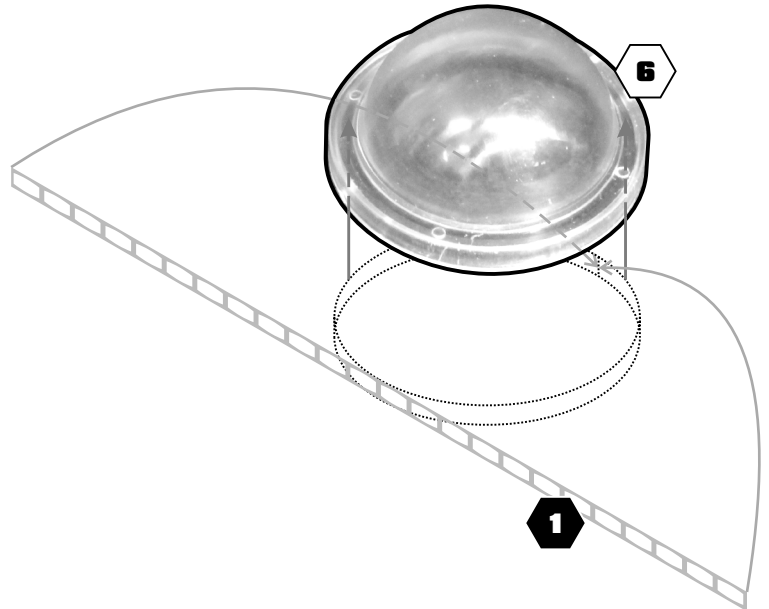

## Lower Hull Details

### Ballast Vents

Repeat on both sites.

Remove the four raised vents from the lower hull (kit part 2) and replace with photoetched vents (either 48 or the assembly of 2 and 25).

Attach water intake screen (26) in place of kit parts 92. (You may want to fill the hole before mounting the parts.

Airlock Indicator

Mount the airlock indicator (etch part 4) just in front of the airlock door.

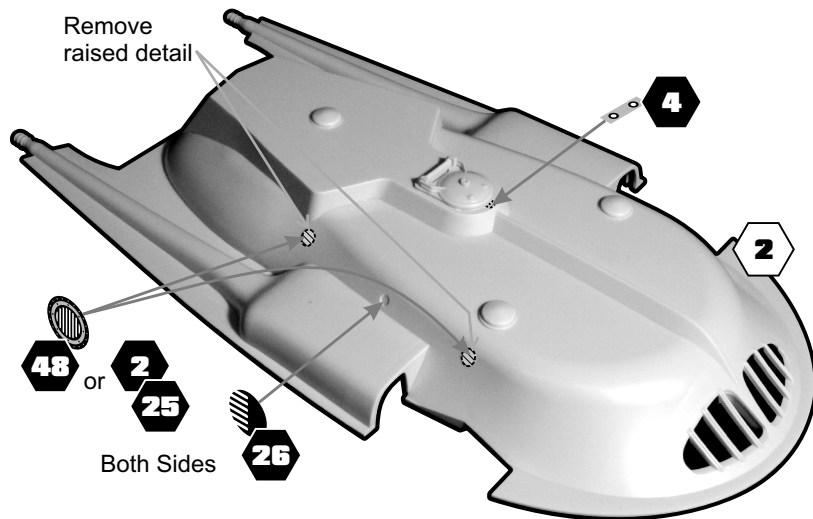

**PARA  
GRAFIX™**

ParaGrafix, Inc.  
Attleboro MA 02703 USA  
+1 508-431-9800  
www.ParaGrafix.biz